

DS 500

ELITE

OMNIWASH®



ELITE DS

DOPPIA PARETE - DOUBLE SKIN - DOUBLE PAROI - DOPPELWANDIG - DOBLE PARED



CARATTERISTICHE GENERALI

- Esecuzione in AISI 304 -18/10
- Dosatore brillantante incorporato
- Molle ed ammortizzatori porte
- Caricamento automatico
- Resistenze in Incoloy
- Pulsante per risciacquo a freddo
- Doppia girante di lavaggio e risciacquo
- Ugelli di lavaggio e risciacquo smontabili per una perfetta pulizia
- Microinterruttore di sicurezza porta
- Termostato di sicurezza sul boiler
- Pompe di lavaggio esclusive ad altissimo rendimento
- Boiler speciale per un perfetto risciacquo ad alta temperatura

DOTAZIONE

- 1 Cesto 18 piatti
- 1 Cesto bicchieri
- 1 Cesto porta posate

OPZIONI

- Pompa scarico
- Dosatore regolabile per detersivo



GENERAL CHARACTERISTICS

- AISI 304 18/10 stainless steel construction
- Automatic rinse-aid injector included
- Springs and pads for easy door opening/closing
- Automatic filling and heating
- Incoloy heating elements
- Cold rinse facility
- Double wash and rinse arms
- Wash and rinse jets removable for easy cleaning
- Door safety switch
- Boiler safety thermostat
- High efficiency wash pump
- Special boiler design to give higher rinse temperature

SUPPLIED WITH

- 1 Basket for 18 dishes
- 1 Basket for glasses
- 1 Basket for basket

OPTION

- Drain pump
- Adjustable detergent dispenser



TECHNIQUES GENERALES

- Réalisation en AISI 304 18/10
- Doseur de produit de rinçage incorporé
- Ressorts et amortisseurs de porte
- Chargement automatique
- Résistances en Incoloy
- Poussoir de rinçage a froid
- Double bras de lavage et rinçage
- Gicleurs de lavage et rinçage démontables pour une nettoyage parfaite
- Micro sécurité porte
- Thermostat de sécurité pour la résistance du surchauffeur
- Pompes de lavage exclusives très performantes
- Surchauffeur spécial pou un parfait rinçage à haute température

DOTATION

- 1 Panier assiettes
- 1 Panier verres
- 1 Godet porte couverts

OPTION

- Pompe de vidange
- Doseur produit de lavage



ALLEGEMEINE EIGNSCHAFTEN

- Ausführung aus CNS (1.4301)
- Eingebaut Dosiervorrichtung für Glanzmittel
- Ausbalancierte Tür mit Federn
- Automatische Füllung
- Incoloy Heizungselement
- Kaltwassernachspülung
- Rotierende Nachspülung, oben und unten
- Wash und Nachspüldüsen demontierbar
- Türsicherheitsschalter
- Boilersicherheitsschalter
- Hochleistung washpumpen
- Spezial Boiler für eine perfekte Nachspülhochtemperatur

AUSSTATTUNG

- 1x18 Teller Korb
- 1 Gläser Korb
- 1 Besteckbehälter

OPTION

- Ablaufpumpe
- Reinigermitteldosierung



CARACTERISTICAS GENERALES

- Construido en AISI 304 18/10
- Dosificador de abrillantador incorporado
- Muelles y amortiguadores de puerta
- Carga automática
- Resistencias en Incoloy
- Tecla para aclarado en frío
- Doble brazo giratorio
- Toberas de lavado y aclarado desmontables por una perfecta limpieza
- Micro paro puerta
- Termostato de seguridad de calderin
- Bombas de lavado exclusivas de alto rendimiento
- Calderin especial para un perfecto aclarado en alta temperatura

DOTACIÓN

- 1 Cesta para platos
- 1 Cesta para vasos
- 1 Cesta para cubiertos en los lavaplatos

OPCIONAL

- Bomba de descarga
- Dosificador de detergente regulable



- Ugello per introduzione detersivo
- Detergent nozzle
- Spülungseintritt serienmäßig montiert
- Gicleur produit lessiviel
- Tobera para introducción del detergente



CARATTERISTICHE TECNICHE	TECHNICAL DATA
Alimentazione elettrica	Electric supply
Potenza pompa lavaggio	Wash pump power
Portata pompa lavaggio	Wash pump flow rate
Resistenza boiler	Boiler heating element
Resistenza vasca	Tank heating element
Potenza massima assorbita	Total power rating
Capacità vasca	Wash tank capacity
Capacità boiler	Boiler capacity
Temperatura lavaggio/risciacquo	Wash/Rinse temperature
Durata ciclo	Cycle time
Cicli ora	Cycles/hour: up to
Pressione alimentazione	Required water pressure
Ø tubo di carico	Water supply hose
Ø tubo di scarico	Drain hose diameter
Misure cesto quadro	Square basket size
Produzione oraria (bicchieri)	Hourly output (glasses) up to
Produzione oraria (piatti)	Hourly output (dishes) up to
Peso	Weight

Dati tecnici non impegnativi - Technical data can be modified without notice

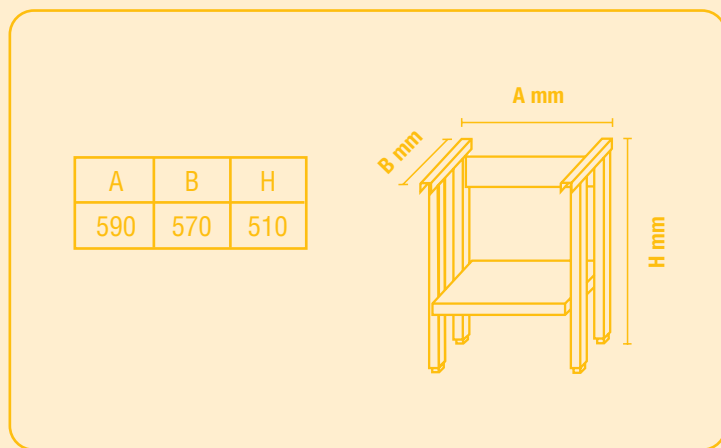
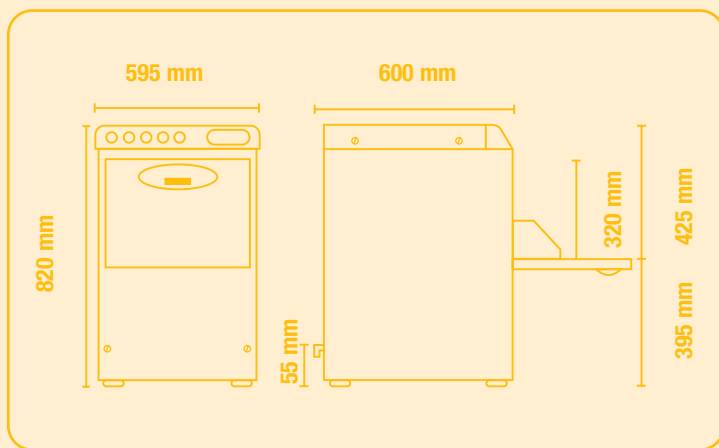

ELITE DS 500

CARACTERISTIQUES TECHNIQUES	TECNISCHE EIGENSCHAFTEN	CARACTERISTICAS TÉCNICAS	ELITE DS 500
Alimentation électrique	Betriebsspannung	Alimentación eléctrica	3x230 - 400V + N
Puissance pompe de lavage	Pumpenleistung	Potencia bomba lavado	Kw 0,75 (HP 1)
Débit de la pompe	Durchfluss Pumpe	Volumen bomba	lt. 420/min
Puissance résistance surchauffeur	Heizleistung Boiler	Potencia resistencia boiler	W 6000
Puissance résistance cuve	Heizleistung Wanne	Potencia resistencia cuba	W 2500
Puissance maximale	Max Stromaufnahme	Potencia máxima	W 6750
Capacité cuve	Wanneninhalt	Capacidad cuba	lt 30
Capacité surchauffeur	Boilerinhalt	Capacidad boiler	lt 8
Température lavage/rincage	Wasch/Spültemperatur	Temperatura lavado/aclarado	55°/85°
Durée du cycle	Wasch/Spülzyklusdauer	Duración ciclo	120/240 sec.
Cycles par heure	Zyklus pro Stunde	Ciclos/h	30/15
Pression alimentation	Wasserzulaufdruck	Presión alimentación	bar 2÷4
Diamètre tuyau d'entrée	Einfüllschlauch	Ø tubo de carga	3/4"
Diamètre tuyau de vidange	Ablaufschlauch	Ø tubo de descarga	32
Dimensions panier carré	Eckiger Korbgröße	Medida cesta cuadrada	50x50
Production par heure (verres)	Stundendurchsatz (gläser)	Producción horaria (vasos)	1500
Production par heure (assiettes)	Stundendurchsatz (teller)	Producción horaria (platos)	540/270
Poids	Netto Gewicht	Peso	75