

35E-A35E - 40E-50E

MAGIC

*Professional Quality*

**COOL™**  
EQUIPMENT

**OMNIWASH®**



**MAGIC**

LAVASTOVIGLIE - DISHWASHERS - LAVE VAISSELLE - GESCHIRRSPÜLER - LAVAPLATOS  
LAVABICCHIERI - GLASSWASHERS - LAVE VERRES - GLÄSERSPÜLER - LAVAVASOS



### CARATTERISTICHE GENERALI:

- Dosatore brillantante incorporato
- Caricamento automatico
- Resistenza in Incoloy
- Pulsante per risciacquo a freddo
- Ugelli di lavaggio e risciacquo smontabili per una perfetta pulizia
- Microinterruttore di sicurezza porta
- Termostato di sicurezza sul boiler
- Pompe di lavaggio esclusive ad altissimo rendimento
- Boiler speciale per un perfetto risciacquo ad alta temperatura



### ALLEGEMEINE EIGENSCHAFTEN

- Eingebaut Dosiervorrichtung für Glanzmittel
- Automatische Füllung
- Incoloy Heizungselement
- Kaltwassernachspülung
- Wash und Nachspüldüsen demontierbar
- Türsicherheitsschalter
- Boilersicherheitsschalter
- Hochleistung washpumpen
- Spezial Boiler für eine perfekte Nachspülhochtemperatur



### CARACTERISTICAS GENERALES

- Dosificador de abrillantador incorporado
- Carga automática
- Resistencias en Incoloy
- Tecla para aclarado en frío
- Toberas de lavado y aclarado desmontables por una perfecta limpieza
- Micro paro puerta
- Termostato de seguridad de calderin
- Bomba de lavado exclusivas a alto rendimiento
- Calderin especial para un perfecto aclarado en alta temperatura



### GENERAL CHARACTERISTICS

- Automatic rinse-aid injector included
- Automatic filling & heating
- Incoloy resistances
- Cold rinse facility
- Wash and rinse nozzles removable for easy cleaning
- Door safety switch
- Boiler safety thermostat
- High efficiency wash pumps
- Special shaped boiler to ensure high rinse temperature



### CARACTERISTIQUES TECHNIQUES GENERALES

- Doseur de produit de rinçage incorporé
- Chargement automatique
- Résistances en Incoloy
- Pussoir de rinçage à froid
- Gicleurs de lavage et rinçage démontables pour une nettoyage parfaite
- Micro sécurité porte
- Thermostat de sécurité pour la résistance du surchauffeur
- Pompes de lavage exclusives très performantes
- Surchauffeur spécial pou un parfait rinçage à haute température



CARATTERISTICHE TECNICHE	TECHNICAL DATA	CARACTERISTIQUES TECHNIQUES	TECNISCHE EIGENSCHAFTEN
Alimentazione elettrica	Electric supply	Alimentation électrique	Betriebsspannung
Potenza pompa lavaggio	Wash pump power	Puissance pompe de lavage	Pumpenleistung
Portata pompa di lavaggio	Wash pump flow rate	Débit de la pompe	Durchfluss Pumpe
Resistenza boiler	Boiler heating element	Puissance résistance surchauffeur	Heizleistung Boiler
Temperatura acqua	Supply water temperature limits	Température de l'eau	Wassertemperatur
Assorbimento max.	Total power rating	Puissance maximale	Max Stromaufnahme
Capacità vasca	Wash tank capacity	Capacité cuve	Wanneninhalt
Capacità boiler	Boiler capacity	Capacité surchauffeur	Boilerinhalt
Temperatura lavaggio	Wash temperature	Température lavage	Washtemperatur
Temperatura risciacquo	Rinse temperature	Température rinçage	Spültemperatur
Durata ciclo	Cycle time	Durée du cycle	Wash / Spülzyklusdauer
Cicli ora	Cycles/hour: up to	Cycles par heure	Zyklen pro Stunde
Pressione alimentazione (bar)	Supply water pressure	Pression alimentation	Wasserzulaufdruck
Diametro tubo di carico	Water supply hose	Diamètre tuyau d'entrée	Einlaufschlauch
Diametro tubo di scarico	Drain hose diameter	Diamètre tuyau de vidange	Ablaufschlauch
Misure cesti mm	Basket size mm	Dimensions panier mm	Korbgröße
Altezza utile mm	Working height mm	Hauteur porte	Waschbare Höhe
Produzione oraria bicchieri (approx)	Hourly output (glasses) up to	Production par heure (verres)	Stundendurchsatz (gläser)
Produzione oraria piatti (approx)	Hourly output (plates) up to	Production par heure (assiettes)	Stundendurchsatz (teller)
Dotazione cesto bicchieri	Glasses baskets supplied	Dotation paniers verres	Zubehör Gläser Korb
Dotazione inserto piattini	Saucers racks supplied	Dotation support soucoupes	Zubehör Kleinteller Einsatz
Dotazione cestello porta cucchiaini	Baskets for coffee spoons supplied	Dotation petit panier porte cuilleres	Zubehör Teelöffel Korb
Dotazione cestello porta posate	Cutlery racks supplied	Dotation godet porte couverts	Zubehör Besteckbehälter
Dotazione cesto piatti	Plates racks (18 plates) supplied	Dotation panier assiettes	Zubehör 1 x 18 Teller Korb
Dosatore detersivo peristaltico (DD)	Adjustable soap pump	Doseur produit de lavage	Reinigermitteldosierung
Addolcitore (D)	Internal water softener	Adoucisseur incorporé	Eingebauter Wasserenthärker

**MAGIC 35E****MAGIC A35E****MAGIC 40E****MAGIC 50E****CARACTERÍSTICAS TÉCNICAS**

	<b>MAGIC 35E</b>	<b>MAGIC A35E</b>	<b>MAGIC 40E</b>	<b>MAGIC 50E</b>
Alimentación eléctrica	1 x 230 V 50 Hz	1 x 230 V 50 Hz	1 x 230 V 50 Hz	1 x 230 V 50 Hz
Potencia bomba lavado	Kw 0,22	Kw 0,22	Kw 0,45	Kw 0,75
Volumen bomba	lt. 180 / min.	lt. 180 / min.	lt. 240 / min.	lt. 420 / min.
Potencia resistencia boiler	W 2700	W 2700	W 2700	W 2700
Temperatura de agua	min 10 max 50 ° C	min 10 max 50 ° C	min 10 max 50 ° C	min 10 max 50 ° C
Potencia máxima	W 2920	W 2920	W 3150	W 3450
Capacidad cuba	lt. 12	lt. 12	lt. 16	lt. 30
Capacidad boiler	lt. 5	lt. 5	lt. 5,5	lt. 6
Temperatura lavado	55 ° C	55 ° C	55 ° C	55 ° C
Temperatura aclarado	85 ° C	85 ° C	85 ° C	85 ° C
Duración ciclo	150 sec.	150 sec.	150 sec.	150 sec.
Ciclos / h	24	24	24	24
Presión alimentación	bar 2 ÷ 4	bar 2 ÷ 4	bar 2 ÷ 4	bar 2 ÷ 4
Ø tubo de carga	3/4"	3/4"	3/4"	3/4"
Ø tubo de descarga	28	28	28	32
Medida cesta cuadrada	350 x 350	350 x 350	400 x 400	500 x 500
Alteza de lavado	190 mm	250 mm	300 mm	320 mm
Producción horaria (vasos)	600 ÷ 800	600 ÷ 800	800 ÷ 1000	1080
Producción horaria (platos)	-	-	-	432
Dotación cesto para vasos	2	2	2	1
Dotación insertador platos pequeños	1	1	1	-
Dotación insertador cucharillas	1	1	1	-
Dotación cesto para cubiertos en los lavaplatos	-	-	-	1
Dotación cesto para platos	-	-	-	1
Dosificador de detergente regulable	option/opcional	option/opcional	option/opcional	option/opcional
Depurador incorporado	option/opcional	option/opcional	option/opcional	option/opcional

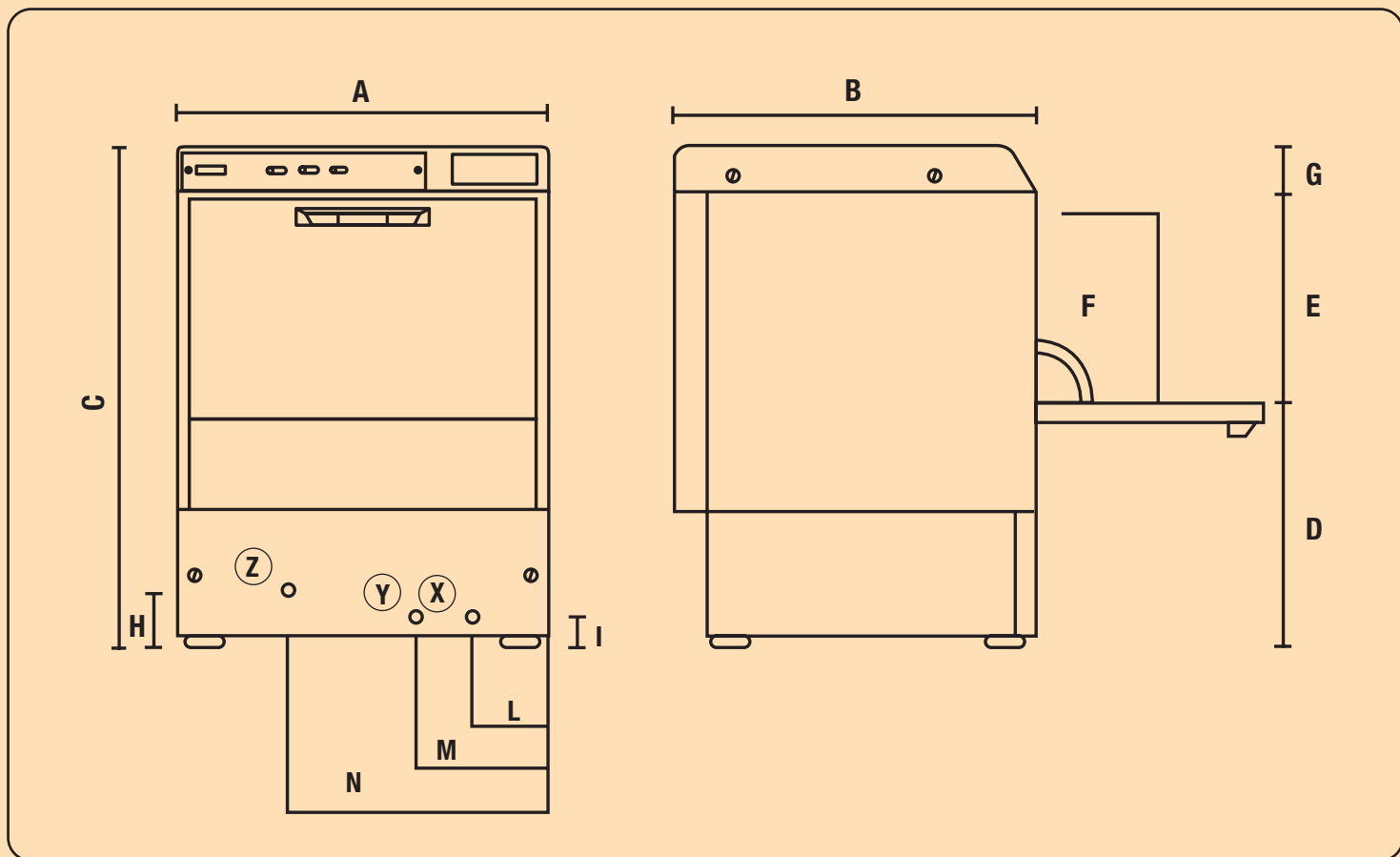

MODELLO	A	B	C	D	E	F	G	H	I	L	M	N
MAGIC 35E	425	455	607,5	330	240	180	37,5	47	47	55	110	260
MAGIC 35E/D	425	455	641,5	330	240	180	71,5	47	47	55	110	260
MAGIC A35E	425	455	667,5	330	300	240	37,5	47	47	55	110	260
MAGIC A35E/D	425	455	701,5	330	300	240	71,5	47	47	55	110	260
MAGIC 40E MAGIC 40E/D	475	505	756,5	330	355	290	71,5	53	53	80	135	285
MAGIC 50E MAGIC 50E/D	590	600	823,5	380	380	320	63,5	56	45	90	170	370

- (X) Entrata acqua di rete - Water inlet
- (Y) Cavo di alimentazione - Supply cable
- (Z) Scarico - Drain outlet

