



Model	GR110K-B0***
Fuel type	Gas
Type	ROTARY OVEN

Specifications.

Number of pizzas 30 cm.	8
Productivity per hour.	120
Gas consumption:	
-methane gas mc / h	3.3
-GPL gas kg / h	1.9
Weight / kg /.	1400
Gas pressure:	
G30-31	37mbar
G20	20mbar
Gas nozzle	3 / 4 "
Thermal power / kw /	26
Electrical supply-230 V/50-60 Hz	

***BO-without heating of the basis

ROTARY GAS OVENS FOR PIZZAS (series GR)

The ovens from GR series are of domical type with a revolving chamber base and are designed for baking pizzas. By rotation of the base of the baking chamber a more uniformed performance, a higher productivity and better work conditions are achieved, since a pizza peel with a shorter handle is used. The rotation speed can be gradually increased and can be reversed as well. Heating up is done by an ecological burner, which works with methane or propane-butane. The power of the burner can be changed by an electronic modulator in the range of 5 to 100 per cents. A circulating fan maintains the optimum temperature of the base. Baking temperature control is electronic with digital indication. Electrical supply - 230 V olt/50-60 Herz. All elements are placed in a metal case which allows the oven to be easily moved.

Dimensions

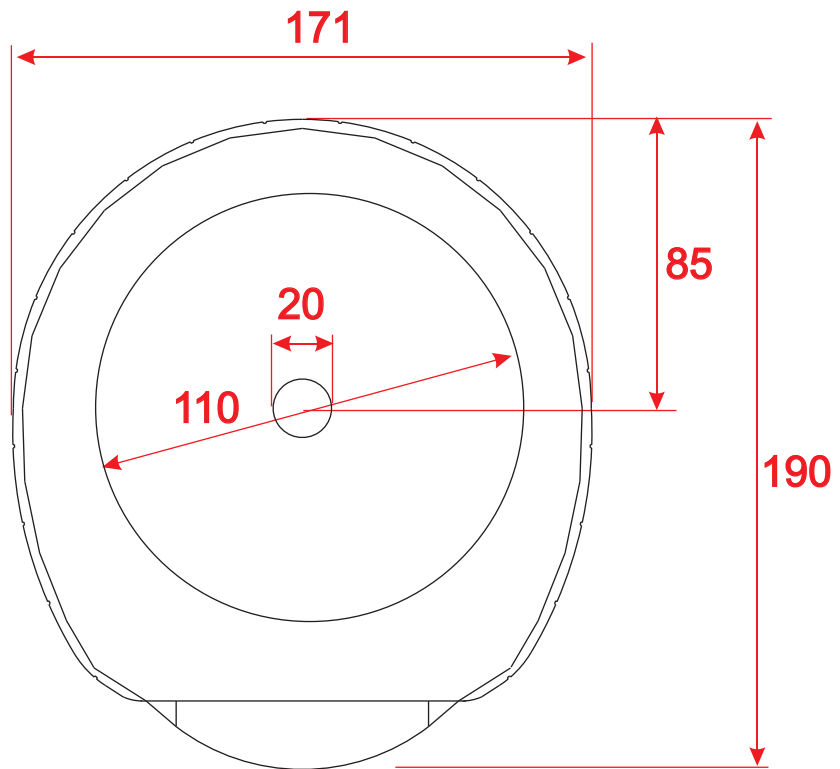
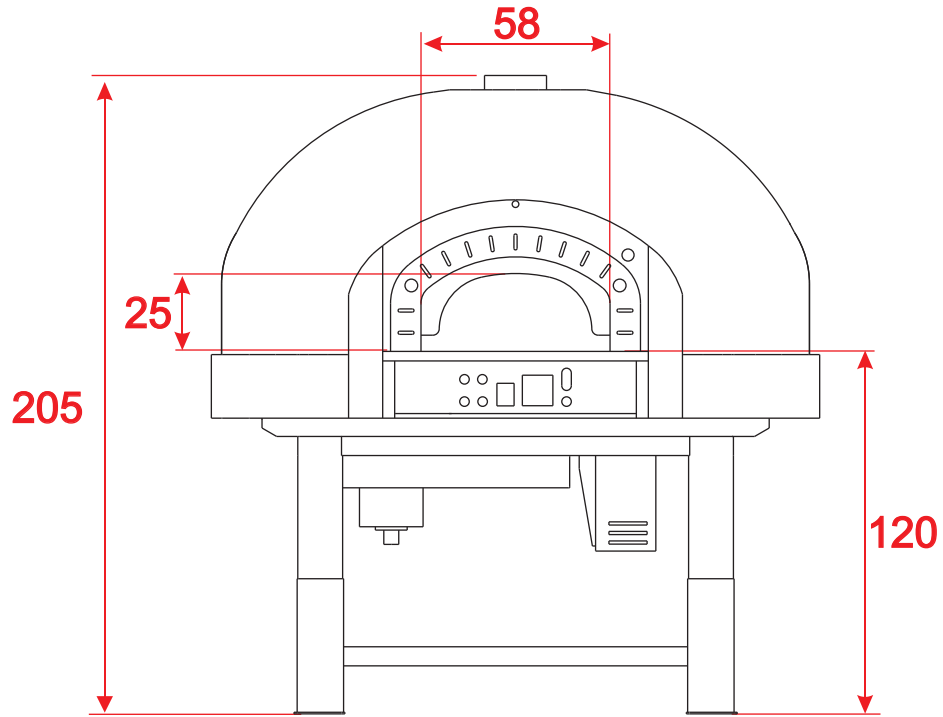

***Dimensions are cm.